

H. WIŚNIEWSKA-WEINERT*#

SURFACE MODIFICATION OF THE HIGH TEMPERATURE POROUS SLIDING BEARINGS WITH SOLID LUBRICANT NANOPARTICLES

MODYFIKACJA POWIERZCHNI POROWATYCH BIEŻNI ŁOŻYSK DO PRACY W WYSOKICH TEMPERATURACH Z ZASTOSOWANIEM NANOCZĄSTEK STAŁEGO SMARU

A surface modification of stainless steel bearing sleeves is developed to improve the tribology characteristics at high temperature. Solid lubricant nano- and microparticles are applied for this purpose. To create the quasi-hydrodynamic lubrication regimes, the solid lubricant powder layer is made by developed pressure impregnation technique. Porous sliding bearing sleeve prototypes were made by powder metallurgy technique. The purpose of the paper is to define the friction and wear characteristics of the sleeves and to determine the influence of sealing of the sliding interface on these characteristics. It is found that application of WS₂ solid lubricant nano- and micro-particles and preservation of a particle leakage out of interface allows to achieve at the high temperature the friction coefficients comparable to those at ambient temperature.

Keywords: bearing sleeves, solid lubricant, powder layer, powder metallurgy, nano- and micro-particles

Opracowano modyfikację powierzchni bieżni łożysk wykonanych ze stali nierdzewnej w celu poprawy charakterystyki tribologicznej w podwyższonej temperaturze poprzez zastosowanie stałego czynnika smarnego w postaci nano- i mikro-cząstek. W celu wytworzenia warunków kwasi-hydrodynamicznego smarowania, wytworzono warstwę z proszku smarnego na drodze infiltracji ciśnieniowej. Celem pracy było wyznaczenie charakterystyki ścierniej i zużyciowej bieżni oraz określenie wpływu uszczelnienia ślizgających się powierzchni na te charakterystyki. Stwierdzono, że zastosowanie WS₂ jako stałego smaru w postaci nano- i mikro-cząstek oraz zabezpieczenie wypływu z granicy fazowej pozwala uzyskać wartość współczynnika tarcia porównywalną z otrzymaną dla temperatury otoczenia.

1. Introduction

Stainless steels are being widely used for manufacturing orthopaedic implants, components of the chemical industry and automotive and aerospace structural components due to their corrosion resistance, good fatigue strength, high fracture toughness and high temperature resistance. However, stainless steels exhibit poor tribology properties (high and unstable friction coefficients against common bearing materials, high friction coefficients and low wear resistance at elevated temperatures). Therefore, a surface treatment, wear resistant and lubrication coatings need to be developed and tried for use of Stainless steels and Ni based alloys. The surface engineering approach of solid lubrication with MoS₂ and WS₂ nanoparticles is discussed in this paper. The

nanoparticle dichalcogenide powders chosen for lubrication are known to be attractive solid lubricants because they exhibit low values of friction coefficients [1,2]. For example, experimental results from a conventional pin-on disk apparatus at low speeds have suggested tungsten disulfide, WS₂, as superior lubricant to molybdenum disulfide, MoS₂, because it maintains a lower coefficient of friction and provides higher wear resistance of counterparts for a higher temperature conditions [2].

Dry particulate materials have been proposed as viable candidates for lubrication in extreme environments (i.e., temperature and/or loads), where conventional lubricants cannot perform [1]. Conventional liquid lubricants are completely ineffective under extremely hot operating conditions (at temperatures greater than 200°C) as they tend to lose their lubricating capability. At the

* METAL FORMING INSTITUTE, 14 JANA PAWŁA II STR., 61-139 POZNAŃ, POLAND

Corresponding author: weinert@inop.poznan.pl

high contact stresses and temperatures, conventional liquid lubricants are unable to withstand the temperatures because of its' destruction [2]. Some engine components suffer poor lubrication at elevated temperatures that presents a serious problem for many mechanical systems such as bearings and piston rings. The similar situation is observed for many aircraft bearings which operates at the temperatures $\geq 500^{\circ}\text{C}$.

The nanopowder lubricants [3] have recently demonstrated excellent lubrication capabilities during sliding at extreme temperatures in the case of use of porous nitrided stainless steel sliding bearings [4]. As shown by Heshmat [2], there are huge technological gains that can be achieved due to characterization of the powder lubricant behavior in high temperature sliding bearings and other friction units. Most lubrication schemes at these higher temperatures have centered on solid lubricants applied as coatings, generated as replenishing films, or introduced as flowing granules. An innovative promising approach has been recently identified as powder lubrication at which granular flow concept has to be applied and studied. The results of Heshmat [2] attests to powders' capability to generate "quasi-hydrodynamic type" pressure and thus yield positive load-carrying capacity. Heshmat's measurements reveal about "powder pressure" in the clearance space of a sliding bearing with very similar features to that of a liquid lubricated bearing. An improvement of sliding bearing performance with solid lubricant powders using Heshmat [2] quasi-hydrodynamic approach and Khonsary et al. [5-7] theory of granular lubrication is still lacking in literature, in particular, for the high temperature conditions. The determination of influence of surface modification of high temperature sliding bearings with solid lubricant nanoparticles on the friction and wear properties of the is shown to be very important, and it is the main goal of this paper, which is continuation of analysis shown in [3].

2. Experimental procedure

2.1. Materials and technology

A real sliding bearing prototype of a hot air valve unit (Fig. 1a) was chosen for experiment. The sliding bearing is supported on housing, and shaft-bearing interface is sealed by spacer and washer that allows to prevent a leakage of solid lubricant powder outside sliding area. MoS₂ solid lubricant powder layer is incorporated onto internal surface of a sliding bearing shown on Fig. 1b. Operating temperatures of the sliding bearing assembling shown on Fig. 1a are in the range of 20-500°C. For this reason the counterparts were made of AISI 316L stainless steel (sleeve) and EZ6NCT25 (shaft). The chemical composition is shown on Table 1.

A compaction-sintering-impregnation-sizing Powder Metallurgy (PM) route was applied to obtain the porous sleeve. The details of technology is described by author in [9]. The samples were made of water atomized AISI 316L austenitic stainless steel powder, which was supplied by Hoganas, with average grain size of 125 μm . The chemical composition of the commercial

powders is shown in Table 1. The powder with 0.6 wt.% of zinc stearate as a lubricant were mixed for 1 h and compacted at 600 MPa to obtain sleeves (drawing is shown on Fig. 1b). They were preheated at 450°C for 30 min to take off the zinc stearate. Sintering was performed at 1250°C in a tubular furnace, in vacuum, for 60 min. After the sintering process, the samples were slowly cooled until room temperature, under vacuum. Afterwards they were nitrided in the furnace JONIMP 900/500. A conventional d.c. glow discharge (DGW) was applied, under a gas mixture of 80% H₂ + 20% N₂ between the workpiece (cathode) and the furnace walls (anode). This gaseous mixture was applied under a pressure in the range of 6-10 mbar for 10 or 30 h. The voltage and current density were adjusted to maintain the temperature at 550 or 580°C. After the nitriding process, the samples were submitted to slow cooling down under vacuum inside the treatment chamber.

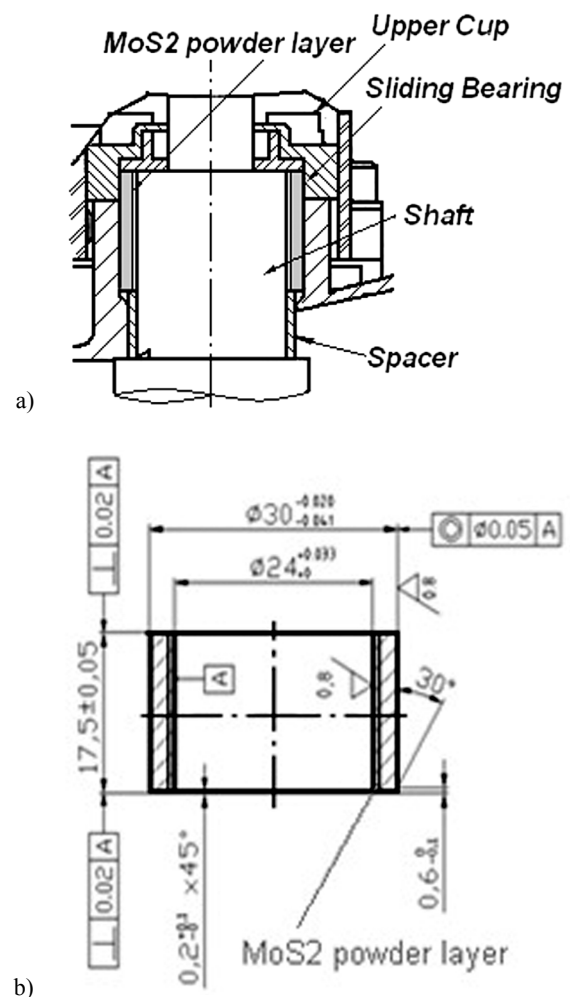

Fig. 1. Sliding bearing assembling (a) and sleeve (b)

TABLE 1

Chemical composition of steels

Material	C	Ni	Cr	Mo	Ti	V	B	Fe
AISI 316L	0,03	12,3	17,4	2,5	0,8	–	–	balance
EZ6NCT25	0,07	27,0	15,5	1,2	2,0	0,30	0,005	balance

As a result of pressure impregnation, following drying at temperature of 150°C during 1 h, and sizing we obtained the porous sliding bearings with MoS₂ and WS₂ solid lubricant powder layers of thickness about 80-100 μm. MoS₂ and WS₂ layers consist of micro- and nanoparticles obtained by method described in detail in [3].

2.2. Structure and properties study

To study microstructure and microhardness the samples were cross-sectioned, mechanically polished and then they were slightly etched with etchant (composition is 20 ml of hydrochloric acid and 80 ml of distilled water). Cross-section micro-hardness profiles were performed by using a Olympic micro-hardness tester equipped with a Vickers indenter, by us-

ing 0.01 kg load, for 15 s. The nitride layer depth was measured optically. The micrographs were taken by using Nikon Eclipse 150L optical microscope and Scanning Electron Microscope FEI. The results of sintered sleeve and shaft characterization are shown in Table 2.

2.3. Friction tests

The sliding bearing samples with MoS₂ powder layer were tested on a home made friction tester TWT 500N which allows to define the friction and wear parameters at the conditions similar to those of real bearing unit used in valve control systems (Fig. 1a). The counterpart is the shaft φ24×35 mm made of EZ6NCT25 steel (mechanical properties are in Table 2). The schematic of a test bench is shown on Fig. 2.

TABLE 2

Material characterization results

Materials	Porosity %	Compressive strength MPa	Hardness HB(HV)	Initial Roughness Ra, μm	Roughness after test Ra, μm
Sleeve Powder SS Steel	22.0	850	110-135 HB	2.5	1.7
Sleeve AISI 316+nitriding	18.0	920	900-980 HV	2.0	1.9
Shaft EZ6NCT25	–	1100	277-341HB	1.8	1.5

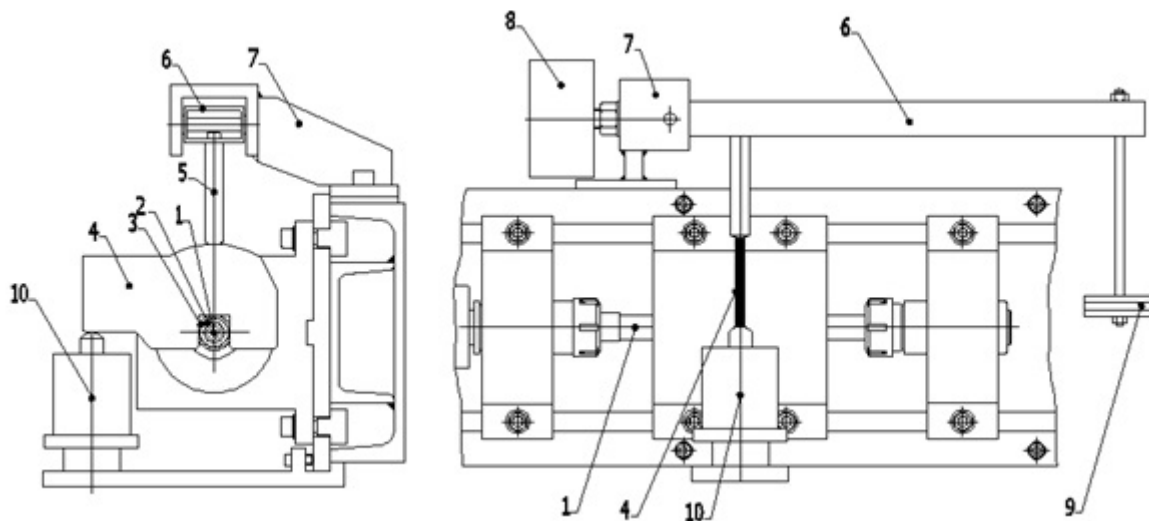

Fig. 2. Tester TWT-500N schematic. 1 – shaft with sample holders, 2 – shaft counterpart, 3 – sliding bearing sleeve, 4 – sleeve holder, 5 – level of loading, 6, 7, 8 – normal loading system, 9 – dead weight, 10 – load cell

The test bench allows to make friction tests of the friction pair shaft-sleeve in real exploitation conditions: speed up to 120rpm, max normal load –500N, test temperature up to 600°C. The parameters to be registered are followings: friction moment, normal load, temperature. Friction coefficient is calculated as

$$\mu = \frac{M}{P \cdot r} \tag{1}$$

where: *M* – friction moment [Nm], *P* – normal load [N], *r* – internal radius [m]. Wear losses are defined on the base of weight change of shaft and sliding bearing.

The characterization of lubrication process was performed on the basis of Stribeck curves analysis that allows defining the lubrication regime at the sliding contact. Stribeck curves were calculated as a friction coefficient dependence on the Sommerfeld number (*S*). For this purpose, the applied normal load was step by step increased by 50 N (every 900 revolutions) starting from 220 N and ending with 970 N. Sommerfeld number was calculated [4] on the basis of from the following formula:

$$S = \frac{\eta \cdot u \cdot r}{p \cdot \varepsilon} \tag{2}$$

where: $p = P/L$, L – a sleeve width, η is powder lubricant viscosity (0.69cP [3]), and u is the entraining velocity of the bearing surface, ε – clearance.

3. Results and discussion

3.1. Sliding bearing design and material structure

The SEM image of sleeve porous structure with deposited solid lubricant particle layer shown on Fig. 3 demonstrates that solid lubricant layer thickness is about 80µm. The porosity of solid lubricant layer is about 12-18% (evaluated by image analysis of SEM micrographs). The porous structure of solid lubricant particulate layer, presence of sub-micro- and nanoparticles and relatively weak bonding of solid lubricant particles allows to accomplish the conditions of particle flow at the contact interface.

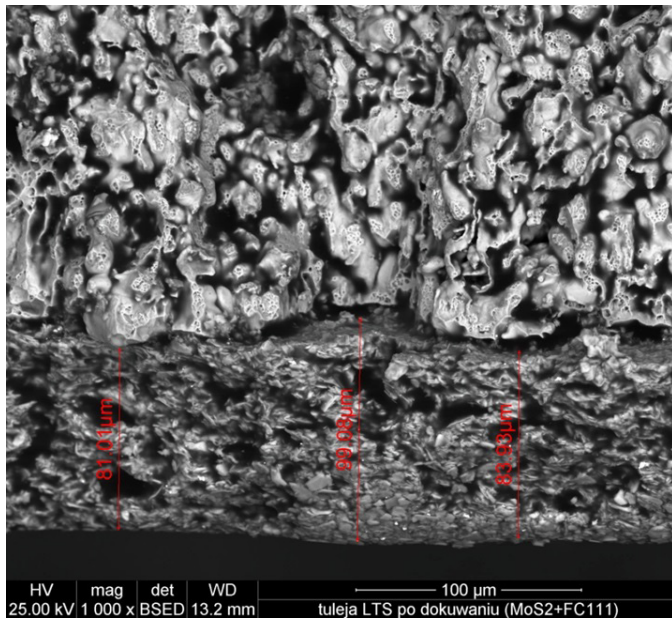

Fig. 3. SEM image of porous sleeve with solid lubricant layer

The solid lubricant layer forms a powder bed (Fig. 4a) in the clearance area at the sliding interface similar to the oil lubricant layer in self-lubricating oil bearings. The main difference between these layers is the accumulation of oil in the pores of the self-lubricating porous bearing. At this case the circulation of oil through the porous channels is achieved and oil leakage from the clearance area is relatively small. In the case of the sliding bearing solid lubrication the circulation of the solid lubricant particles may be accomplished only due to particle flow in the clearance area, as shown on Fig. 4a. It results in pulling out of the solid lubricant particles from the sliding interface due to high normal loads. For this reason the special washers need to be applied to prevent the leakage of the solid lubricant particles. The developed design of sliding bearing unit with sealing of the clearance area is shown on Fig. 4b-c. The graphite rings are applied for this purpose.

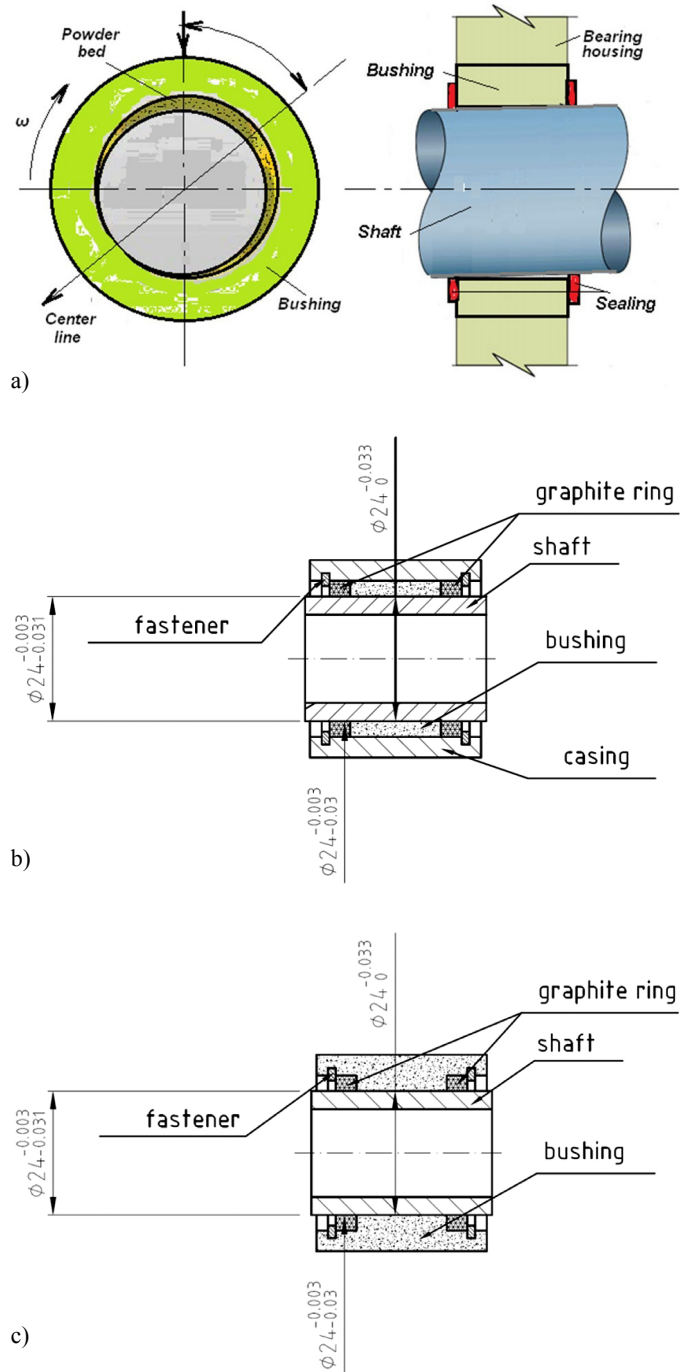
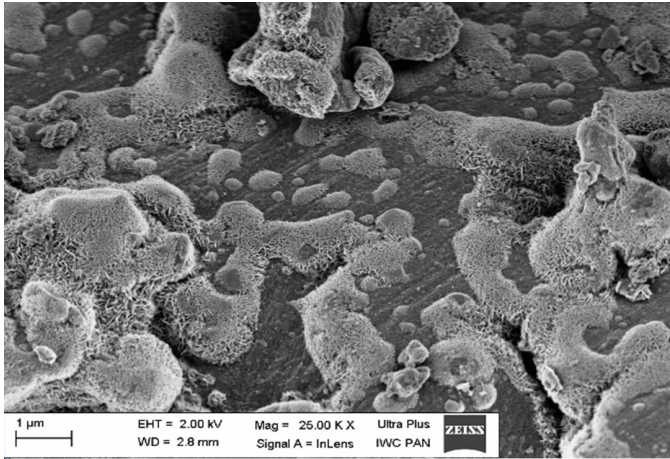

Fig. 4. Sliding bearing unit schematic (a) and design (b, c)

Results of SEM examination of the sliding contact after friction test reveal the presence of WS2 nanoparticles (Fig. 5). The SEM micrographs demonstrates an occurrence of WS2 nanoparticle agglomerates both on the sliding surface (Fig. 5a) and between the WS2 microparticles (Fig. 5b). The platelet shape WS2 nanoparticles formed due to special rolling cleavage technique [4] have sizes about 20 nm and thickness about 2-3 nm. The presence of nanoparticles at the sliding contacts after sliding about 6000 m proves the effectiveness of the sliding interface sealing which allows to preserve flow of the solid lubricant particles out of sliding interface.

The results of the friction tests with the test bench TWT-500 N are shown on Fig. 6. The variation of lubrication regime was reached by increase of normal load that changed the Sommerfeld parameter [4].



a)

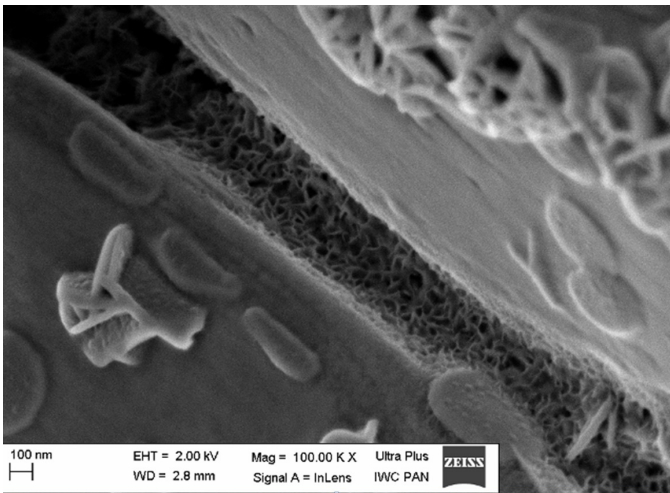

b)

Fig. 5. SEM images of WS2 nanoparticle agglomerates at the sliding contact (the shaft surface)

The Stribeck analysis results shown on Fig. 6b demonstrate that lubrication behavior with application of solid lubricant is similar to that of oil lubricated sliding contact. The stages of boundary, hydrodynamic and mixed lubrication are clearly seen. Thus, the quasi-lubrication regime [3] of high temperature sliding contact is achieved. Moreover, sealed sliding interface exhibits better load bearing capacity than that of open sliding contact. It is interesting to note that oil lubrication regime is less stable than that of solid lubrication. It reveals that the solid lubricant film has more strength than that of solid lubricant, that results in increase of wear resistance of the sealed high temperature sliding couple (Fig. 7).

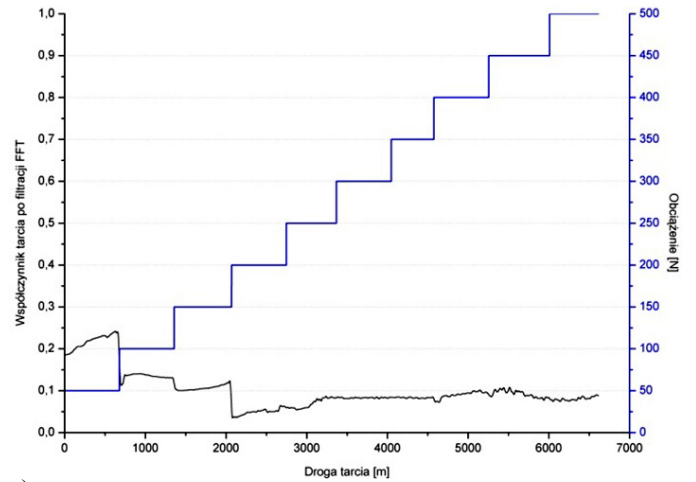

a)

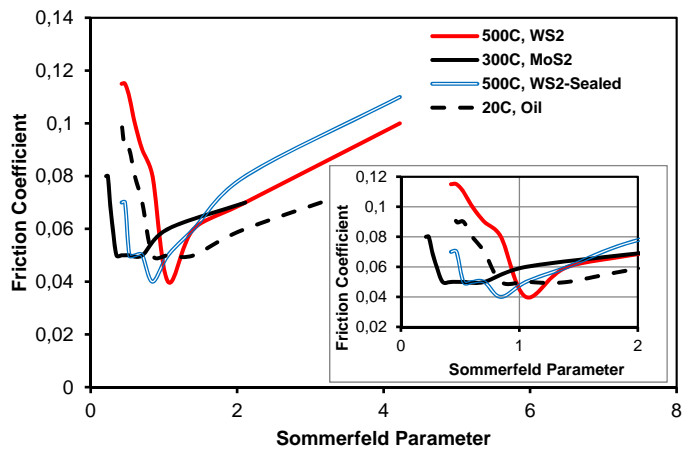

b)

Fig. 6. Friction tests results at the temperatures of 20-500°C (a) – an example of friction coefficient diagram at 500°C for lubrication of the steel sleeve-shaft sealed couple (Fig. 4b) with WS2solid lubricant particles; (b) – Stribeck curves for examined lubrication cases (20°C – oil, 300°C – MoS2, 500°C – WS2, 500°C – WS2 with sealing)

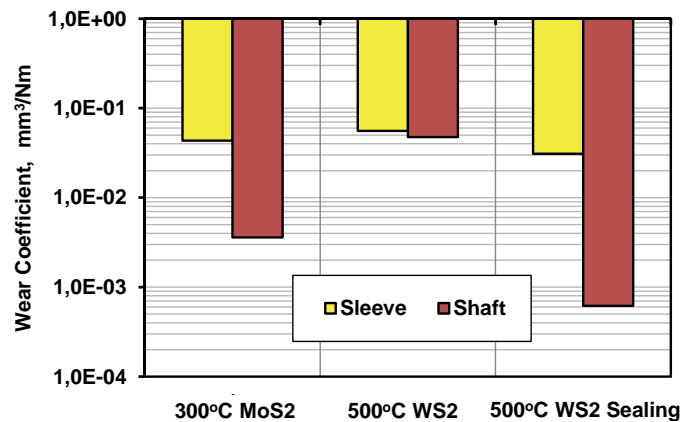

Fig. 7. Wear tests results at the temperatures of 20-500°C

4. Conclusion

The surface modification of the high temperature porous sliding bearings with solid lubricant nanoparticles allows to considerably diminish its' friction coefficient and wear rate. The surface modification technology of powder sintered bearings is developed. It consists of nitriding, pressure impregnation and sizing operations which allow to obtain solid lubricant particulate layer at the sliding surface. It is found the solid lubricant micro- and nanoparticle layer provides the quasi-hydrodynamic lubrication regime at the sliding contact at high temperature.

REFERENCES

- [1] E.Y.A. Worniyoh, V.K. Jasti, C.F. Higgs III, J. Tribol. **129**, 438-449 (2007).
- [2] H. Heshmat, C.A. Heshmat, Tribology S **36**, 537-544 (1999).
- [3] L. Cizaire, B. Vacher, T. Le Mogne, J.M. Martin, L. Rapoport, A. Margolin, R. Tenne, Surface & Coatings Technology **160**, 282-287 (2002).
- [4] H. Wisniewska-Weinert, Powder Metall Met C+ **52**, 424-430 (2013).
- [5] L. Zhou, M.M. Khonsari, J. Tribol. **122**, 147-151 (2000).
- [6] K.T. McKeague, M.M. Khonsari, J. Tribol. **118**, 206-214 (1996).
- [7] M. Pappur, M.M. Khonsari, J. Tribol. **125**, 135-144 (2003).
- [8] H. Wisniewska-Weinert, Arch Civ Mech Eng **14**, 255-261 (2014).

Received: 20 April 2015