

A. GONTARZ*[#], G. WINIARSKI*

NUMERICAL AND EXPERIMENTAL STUDY OF PRODUCING FLANGES ON HOLLOW PARTS BY EXTRUSION WITH A MOVABLE SLEEVE

BADANIA TEORETYCZNO-DOŚWIADCZALNE PROCESU KSZTAŁTOWANIA KOŁNIERZA WE WSADACH DRAŻONYCH METODĄ WYCISKANIA Z ZASTOSOWANIEM RUCHOMEJ TULEI

The paper presents the numerical and experimental results of a new method for producing flanges on hollow parts. With this new method, the flange is extruded by a movable sleeve. This innovative technique is modelled numerically by the finite element method. The effect of workpiece and finished product geometries on the forming process is investigated and failure modes are identified. The numerical results are then verified in experiments. The tests are conducted using a three-slide forging press equipped with a special device. The numerical and experimental results show a good agreement, which proves that the developed method is correct.

Keywords: hollows parts with flanges, extrusion process

W artykule przedstawiono analizę teoretyczno-doświadczalną nowego procesu wytwarzania kołnierzy we wsadach drażonych. Metoda polega na wyciskaniu kołnierza z zastosowaniem ruchomej tulei. Nową metodę poddano analizie teoretycznej, stosując jako narzędzie metodę elementów skończonych. Dokonano analizy wpływu parametrów geometrycznych wsadu i wyrobu końcowego na przebieg kształtowania oraz zidentyfikowano ograniczenia procesu. Weryfikację doświadczalną wykonano na trójsuwakowej prasie kuzniczej, w której umieszczono specjalistyczny przyrząd. Wyniki badań numerycznych oraz doświadczalnych wykazały dobrą zgodność i potwierdziły słuszność zaproponowanej metody.

1. Introduction

Hollow parts are more and more often applied in numerous sectors of industry. Their growing use is dictated by the need to reduce weight and hence price of structures. Hollow parts are widely used as drive shafts for transmitting torsional stresses. Here, it is particularly recommended that hollow billets be used instead of solid ones, because a hollow billet whose outside diameter is 20% larger than that of a solid billet weighs half the weight of its solid counterpart, having identical torsional strength at the same time. Very often, drive shafts have flanges on their ends to enable connecting them to other machine parts, e.g. clutch or engine. Flanges can be produced by numerous techniques, including metal forming, machining and founding methods.

Flanged shafts produced by metal forming have more advantages than shafts with flanges manufactured by other methods. The metal-formed flange and shaft body are both made from the same, solid piece of material, which obviates the necessity of connecting the flange to the tube. Moreover, metal-formed flanges have higher strength properties compared with flanges produced by founding or machining.

With flanges produced by metal forming, it is also possible to considerably reduce material losses from machining allowance.

There are many different methods for producing flanges. This diversity stems from the fact that each of these methods is applied to produce flanges of specific shape and dimensions. The forming methods for producing flanges include:

- tube flanging by two-stage static expanding with rigid tools and by magnetic-pulse forming [1],
- flanging by rotary compression [2],
- flanging by upsetting [3],
- flanging by spinning [4],
- upsetting of free protruding tube ends [5],
- injection forging [6, 7, 8],
- tube-end forming [9],
- flange extrusion by an elastic ring [10, 11],

The paper describes a new method for producing flanges in hollow parts. The method is dedicated to producing flanges whose height is several times larger than workpiece wall thickness.

* LUBLIN UNIVERSITY OF TECHNOLOGY, FACULTY OF MECHANICAL ENGINEERING, DEPARTMENT OF COMPUTER MODELLING AND METAL FORMING TECHNOLOGIES, 36 NADBYSTRZYCKA STR., 20-618 LUBLIN, POLAND

[#] Corresponding author: a.gontarz@pollub.pl,

2. Design of the process for extruding flanges on hollow parts using a movable sleeve

The process for extruding flanges on hollow parts using a movable sleeve is run with the tools shown in Fig. 1. A workpiece 2 is a tube section to be flanged on its end. The said workpiece 2 is put inside a movable sleeve 5 with a hole of varying diameters that correspond to the outside diameters of both the workpiece and flange. The workpiece 2 is supported on a fixed sleeve 4 to prevent its axial displacement during flange extrusion. The forming of the flange begins when a punch 1, which also serves as a mandrel, is set in motion. The said punch is the only tool that moves in the first stage of the forming process. This stage continues until the filling up of a free space 3 between the tools and non-deformed material of the workpiece 2, characterized by height h_0 . The second stage of the process begins when the movable sleeve 5 starts to move in the opposite direction to that of the punch 1. Due to the distance between the movable and fixed sleeves, the free space 3 increases, which increases the height of the flange being formed.

The velocity of the movable sleeve strongly depends on the punch velocity, workpiece dimensions as well as dimensions of the flange being formed. The constant volume criterion can be used to determine both the movable sleeve's velocity, described by dependence (1), and the moment when this sleeve should be set in motion (2):

$$V_t = V_s \cdot \frac{D^2 - d^2}{D_k^2 - D^2}, \tag{1}$$

$$t = \frac{\frac{\pi}{4} \cdot h_0 \cdot (D_k^2 - D^2) + \left(\frac{D}{2} + R\right) \cdot R^2 \cdot \left(2\pi - \frac{\pi^2}{2}\right) - \frac{\pi R^3}{3}}{\frac{\pi}{4} \cdot V_s \cdot (D^2 - d^2)}, \tag{2}$$

where (denotations in accordance with Fig. 1):

- V_t is the velocity of the movable sleeve;
- V_s is the velocity of the punch;
- D is the outside diameter of the workpiece;
- d is the inside diameter of the workpiece;
- D_k is the diameter of the flange;
- h_0 is the initial distance of the movable sleeve from the fixed one;
- R is the edge radius of the movable sleeve.

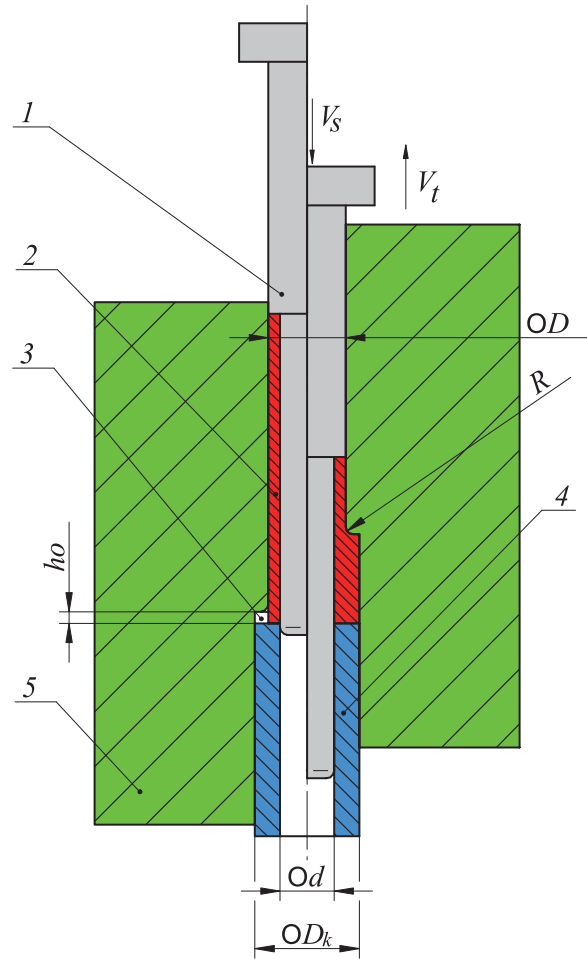

Fig. 1. Design of the device for extruding flanges: 1 – punch, 2 – workpiece, 3 – space between the tools, 4 – fixed sleeve, 5 – movable sleeve, V_t – velocity of the movable sleeve, V_s – velocity of the punch, D – outside diameter of the workpiece, d – inside diameter of the workpiece, D_k – diameter of the flange, h_0 – initial distance between the movable and fixed sleeves, R – edge radius of the movable sleeve

3. Assumptions for numerical modeling

The numerical modeling of producing a flange by extrusion with a movable sleeve was performed using Deform-3D. The punch, movable and fixed sleeves were assumed to be rigid objects, while the billet was a plastic object divided into tetragonal (four-node) elements and assigned the properties of a rigid-elastic material. Both in the numerical modeling and experiments, the billet was made of lead, its material properties obtained from the Deform-3D material database library. The workpiece was a tube section with the following dimensions: $\varnothing 14 \text{ mm} \times \varnothing 20 \text{ mm} \times 80 \text{ mm}$. The numerical modeling was performed for flanges with varying diameters and varying initial distance between the movable and fixed sleeves (Table 1). The workpiece-tools contact was defined by the constant friction model with the friction factor, m , set to 0.8. In all simulation variants, the punch velocity, V_s , was 10 mm/s . The velocity of the movable sleeve and the moment of starting it were determined by means of dependence (1) and dependence (2), respectively.

TABLE 1
Variables for numerical modeling

Billet dimensions: Ø 14mm x Ø 20 mm x 80 mm			
Flange diameter, D_k	Ø27	Ø28	Ø30
Initial distance h_o between the movable and fixed sleeves	1.5	1.5	1.5
	3	3	3
	3.5	3.5	3.5
	4	4	4
	4.5	4.5	4.5
	6	6	6

4. Numerical results

The numerical results were examined with regard to failure modes. The main observed defect is overlap which is produced either in the first or in the second stage of the process. The overlap produced in the first stage of extrusion occurs when the distance h_o of the movable sleeve from the fixed sleeve is too high (detail a in Fig. 2).

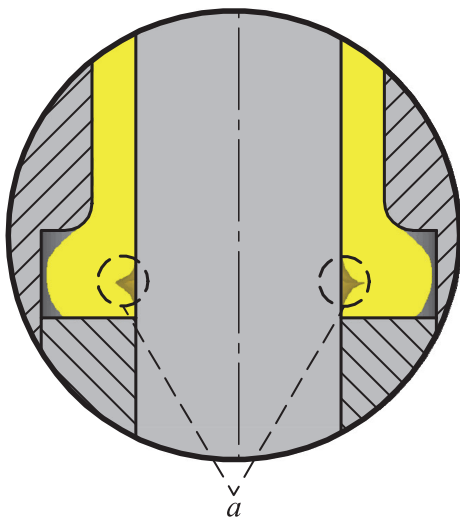

Fig. 2. Overlap produced in the first stage of flange extrusion.

The above overlap occurs for every flange-diameter variant and at different values of h_o . The numerical results are compared in Table 2, where the sign “-” denotes lack of overlap, while “+” means that overlap has occurred.

The numerical results demonstrate that the overlap produced in the first stage of the process does not bring about any negative effects further on. After the space 3 has been completely filled up (Fig. 1), the flange-forming process continues and no further negative phenomena are observed. In other words, the defect occurs only in the region of the flange where the height does not exceed h_o , whereas the rest of the flange has the correct shape. Since the flange region with the overlap can be removed by machining, the finished product can have the desired shape despite the initial defect.

TABLE 2
Occurrence of overlap in the first stage of flange extrusion

Initial distance h_o between the movable and fixed sleeves, mm	Flange diameter, D_k , mm		
	Ø27	Ø28	Ø30
1.5	-	-	-
3	-	-	-
3.5	-	-	-
4	-	+	+
4.5	+	+	+
6	+	+	+

The overlap produced in the second stage of the process is illustrated in Fig. 3, detail a. The defect occurs on face end of the flange adjacent to the movable sleeve. This defect is produced when the velocity of the movable sleeve is too high or when this sleeve is set in motion too early, i.e. before the workpiece material has completely filled up the space 3 between the tools (Fig. 1). In effect, the contact between the face end of the flange and movable sleeve is prevented, which leads to the production of a free space between them. This, along with the friction force generated between the flange flank and movable sleeve as well as the sleeve’s motion opposite to that of the punch, alter the kinematics of material flow, which results in overlapping.

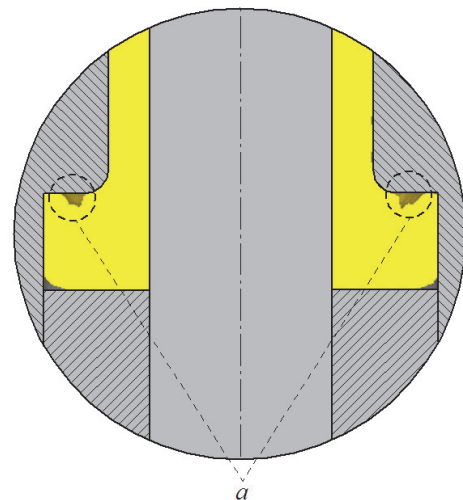

Fig. 3. Overlap produced in the second stage of flange extrusion

5. Experimental

The new method for producing flanges was verified in experiments performed using a three-slide forging press (Fig. 4). This machine is suitable for forming complex-shaped products. The forming process is done using three slides (one vertical slide and two side slides) driven by autonomous hydraulic cylinders. The ejector for the removal of finished products is mounted in the bottom part of the press. The ejector is driven by the bottom hydraulic cylinder. The movable elements of the press are driven by a hydraulic apparatus operated from a control panel.



Fig. 4. Three-slide forging press

The extrusion process is done by the two side cylinders. Fig. 5 shows the device which was mounted in the three-slide forging press. The punch is fastened to the left slide of the press, while the right slide drives the movable sleeve. Fig. 6 presents the axial section of the device in order to illustrate its operation.

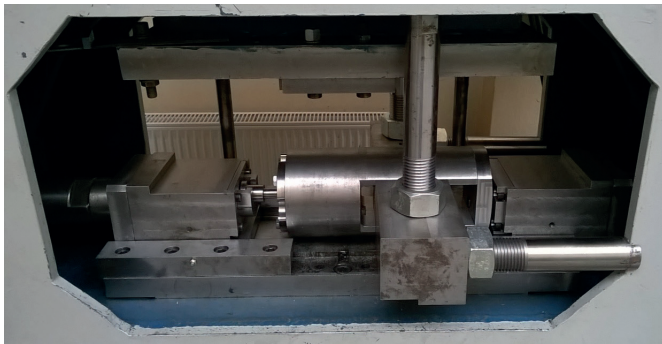

Fig. 5. Device for extrusion with a movable sleeve mounted in a three-slide forging press

The workpiece 4 (Fig. 6) is placed inside the movable sleeve 3. The said movable sleeve 3 is put inside the sleeve 6 that is fastened to the right slide 1b of the press. To produce a flange, the left slide with the punch 2 is set in motion. To prevent axial displacement of the workpiece caused by the punch work, a fixed cross-beam 7 is applied in order to block axial motion of the workpiece via the fixed sleeve 5. The application of this device enables the use of replaceable movable sleeves 3 to form flanges with different diameters.

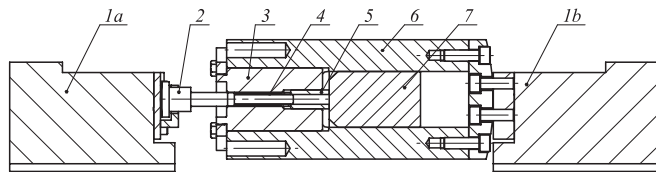

Fig. 6. Section of the device for extrusion with a movable sleeve

The experimental tests of extrusion with a movable sleeve were performed on lead tubes with the dimensions: $\varnothing 14$ mm x $\varnothing 20$ mm x 80 mm (Fig. 7). The initial distance of the movable sleeve from the fixed one was assumed to be equal to thickness of the workpiece wall ($h_0 = 3$ mm).

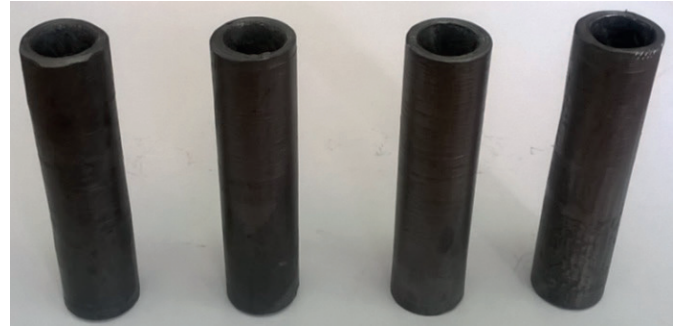

Fig. 7. Billets for flanging

In the experiments, we produced sleeves with flanges that have a diameter of $\varnothing 27$ mm, as shown in Fig. 8. These specimens are free from overlap that occurs in the first stage of extrusion, which agrees with the numerical results. Specimen no. 2 exhibits overlap that was generated in the second stage of the process. Specimens nos. 1, 3 and 4 have the desired shape and are free from overlap or other shape defects.



Fig. 8. Flanged sleeves

As can be seen from Table 3, the produced flanges have different heights. The results demonstrate that flanges produced in one work cycle of the press have the height $H = (5 \div 7.3) g$ (where g denotes the workpiece wall thickness).

TABLE 3

Experimental flange heights				
Specimen no.	1	2	3	4
Flange height, mm	22	20	17	15

6. Conclusion

The paper presents a new method for forming flanges on hollow parts. The method consists in producing flanges by extrusion with a movable sleeve to prevent buckling. Due to the application of the movable sleeve, we can produce flanges whose height is several times larger than workpiece wall thickness.

The constant volume criterion was applied to the set workpiece and tool dimensions in order to determine the relationship between the velocity of the movable sleeve and the punch velocity as well as to estimate the moment when the sleeve should be set in motion.

Based on the numerical results, we identified failure modes including buckling, inside overlap in the first stage of the process, as well as outside overlap that occurs on the upper surface of the flange during the second stage of extrusion.

The results also helped determine the range of geometrical parameters that prevents the above defects from occurring. It was found that the key parameter that affects workpiece wall thickness and flange diameter is the initial distance of the movable sleeve from the fixed one.

The experimental results confirm that the new method is an effective way of producing flanges on hollow parts. The flanges produced during one work cycle of the press have the desired shape and their height is over five times larger than thickness of the workpiece wall. It should be emphasized that the new method enables the production of flanges with relatively large diameters and/or heights, which is the main advantage of this method over other metal forming techniques.

Acknowledgements

Financial support of Structural Funds in the Operational Programme - Innovative Economy (IE OP) financed from the European Regional Development Fund - Project "Modern material technologies in aerospace industry", Nr POIG.01.01.02-00-015/08-00 is gratefully acknowledged.

Grzegorz Winiarski - Participant in the project "Qualifications for the labour market – Lublin University of Technology as an employer-friendly place" co-financed by the European Union as part of the European Social Fund.

REFERENCES

- [1] W. Muzykiewicz, J. Bednarczyk, A. Łukaszka, A. Rękas, Wywijanie kołnierzy elementów rurowych sztywnymi narzędziami w warunkach statycznych i metodą tłoczenia elektrodynamicznego, *Rudy i Metale Nieżelazne* **R47**, 10-11, 545-550 (2002).
- [2] G. Samołyk, Sposób i narzędzia do wywijania końca rury z jednoczesnym prasowaniem obwiedniowym, *Polskie zgłoszenie patentowe nr P.394431*, 2011.
- [3] Hu X.L., Z.R. Wang, Numerical simulation and experimental study on the multi-step upsetting of a thick and wide flange on the end of pipe, *Journal of Materials Processing Technology* **151**,321-327 (2004).
- [4] Fouly A. Mohamed, Sausy Zein El-Abden, A.R. Mohieled, A rotary flange forming process on the late using a ball-shaped tool, *Journal of Materials Processing Technology* **170**,501-508 (2005).
- [5] Zhongjin Wang, Jun Lu, Z.R. Wang, Numerical and experimental research of the cold upsetting-extruding of tube flanges, *Journal of Materials Processing Technology* **110**, 28-35 (2001).
- [6] Raj Balendra, Yi Qin, Injection forging: engineering and research, *Journal of Materials Processing Technology* **145**, 189–206 (2004).
- [7] Yanling Ma, Yi Qin, Raj Balendra, Upper-bound analysis of the pressure-assisted injection forging of thick-walled tubular components with hollow flanges, *International Journal of Mechanical Sciences* **48**, 1172–1185 (2006).
- [8] Yi Qin, Raj Balendra, Optimisation of the lubrication for the extrusion of solid and tubular components by injection forging, *Journal of Materials Processing Technology* **135**, 219–227 (2003).
- [9] M.L. Alves, B.P.P. Almeida, P.A.R. Rosa, P.A.F. Martins, End forming of thin-walled tubes, *Journal of Materials Processing Technology* **177**, 183–187 (2006).
- [10] S. Thiruvardchelvan, M.J. Tan, Collar drawing using a urethane pad, *Journal of Materials Processing Technology* **147**, 139–144 (2004).
- [11] S. Thiruvardchelvan, M.J. Tan, Investigations into collar drawing using urethane pads, *Journal of Materials Processing Technology* **191**, 87–91 (2007).

Received: 20 January 2015.

