

A. BALCERZAK*

A NEW NANOPOROUS MATERIAL IN CHEMICAL SENSOR FOR VAPORS OF SOME VOLATILE ORGANIC SOLVENTS

NOWY MATERIAŁ NANOPOROWATY W CZUJNIKU CHEMICZNYM DO PAR WYBRANYCH LOTNYCH ROZPUSZCZALNIKÓW ORGANICZNYCH

A new material has been proposed as a chemosensitive layer in the surface acoustic wave sensor for vapors of some volatile organic solvents. This material has been fabricated from the bicomponent mixture of 5-[[1,3-dioxo-3-[4-(1-oxooctadecyl) phenyl] propyl] amino]-1,3-benzenedicarboxylic acid and cetylamine. In the Langmuir-Blodgett process a nanolayer of the mixture has been deposited on a piezoelectric substrate with interdigital transducers. Subsequently, the molecules of cetylamine have been removed from the layer leaving nanopores. Sensing properties of this layer for the vapors of some volatile organic solvents in air have been investigated.

Keywords: monomolecular Langmuir-Blodgett layers, volatile organic solvents, surface acoustic wave sensors

Zaproponowano nowy materiał na warstwę chemoczułą czujnika do wykrywania par wybranych lotnych rozpuszczalników organicznych, wykorzystującego akustyczną falę powierzchniową. Materiał ten został wytworzony z dwuskładnikowej mieszaniny kwasu 5-[[1,3-diookso-3-[4-(1-oksooktadecylo) fenyl] propyl] amino]-1,3-benzenodikarboksylowego i cetyloaminy. Osadzono nanowarstwę tej mieszaniny na podłożu piezoelektrycznym z przetwornikami międzypalczastymi stosując proces Langmuira-Blodgett. Następnie cząsteczki cetyloaminy zostały usunięte z warstwy pozostawiając po sobie nanopory. Zbadano wrażliwość tej warstwy na pary wybranych lotnych rozpuszczalników organicznych w powietrzu.

1. Introduction

In science and technology, volatile organic solvents (VOS) are used widely, and their application is essential. Leakage and injury to installations that cause the air contamination by vapors of the VOS are difficult to eliminate. Moreover, in many cases, the VOS are also harmful and flammable. A possibility of measurements of a vapor concentration of the VOS in the atmospheric air can affect the safety of a staff in places, where the VOS are used. In case of this leakage the proper actions or procedures can be applied due to information obtained from the ultrasonic sensors with properly chosen sensor layer.

Different physical and chemical parameters can be measured when the thin layer of a substance sensitive to a measured factor is placed on the piezoelectric substrate [1]. During the physical or/and chemical interaction between this layer and the measured factor, the layer changes its acoustical, mechanical and electrical properties. Subsequently, these properties modify the ultrasonic

signals, which are converted into the electrical signals. Parameters of these signal, especially frequency, voltage and current can be easily measured. Moreover, the electrical signals are very convenient for the data processing.

The Langmuir-Blodgett (L-B) method allows to obtain layers with the monomolecular thickness and deposit them on the substrate [2-4]. The total thickness of the sensor layer can be controlled very strictly. These layers are highly ordered in the molecular sense due to interactions of the deposited molecules with the water surface. This feature enables to expose the molecule moiety of the sensor layer on the influence of an analyzed substance i.e. an analite [5-7].

Many new materials, for instance the molecular imprinted polymers [8], carbon nanotubes [9], lipids [10], liquid crystals [11], supramolecular compounds from groups of phtalocyanines [12], porphyrines [13], cyclodextrines [14], calixarenes [15] and cyclofanen [16] have been applied as the chemosensitive layers for detection of the VOS.

In this work the porous L-B film have been inves-

* INSTITUTE OF FUNDAMENTAL TECHNOLOGICAL RESEARCH PAS, 02-106 WARSZAWA, 5B PAWIŃSKIEGO STR., POLAND

tigated as the chemosensitive layer covering the surface acoustic wave (SAW) sensor for detection of the vapors of some VOS in the atmospheric air. The porous structure of the L-B layer should change its sensing properties.

$$\Delta f = \left(\frac{\partial f}{\partial m}\right) \cdot \Delta m + \left(\frac{\partial f}{\partial c}\right) \cdot \Delta c + \left(\frac{\partial f}{\partial \varepsilon}\right) \cdot \Delta \varepsilon + \left(\frac{\partial f}{\partial \sigma}\right) \cdot \Delta \sigma + \left(\frac{\partial f}{\partial T}\right) \cdot \Delta T + \left(\frac{\partial f}{\partial P}\right) \cdot \Delta P, \quad (1)$$

where Δm , Δc , $\Delta \varepsilon$, $\Delta \sigma$, ΔT and ΔP denote the changes of mass, visco-elasticity, dielectric constant, electrical conductivity, temperature and pressure, respectively. These changes effect the ultrasonic wave propagation, and subsequently the frequency of the generator, in which the sensor delay line is an element of positive feedback. The frequency change can be expressed as:

$$\frac{\Delta f}{f_0} = \frac{\Delta v}{v_0}, \quad (2)$$

where v is the wave velocity and subscript „0” denotes the initial state not disturbed by the interaction of the analite with sensor layer. In most cases the mass of the sensor layer is changed by bonding of the analite molecules with the sensor layer. This bonding can be caused by absorption, diffusion, saturation or condensation. In this case:

$$\Delta f = -k_m \cdot f_0^2 \cdot \frac{\Delta m}{A}, \quad (3)$$

where k_m is a constant, $\Delta m/A$ – the mass of analite bonded with the sensor layer per surface unit. The value of $\Delta m/A$ is connected with the analite concentration in the atmosphere near the sensor, and is governed by the generalized physicochemical process.

In the sensor considered in this paper, the SAW delay line was configured as the resonating and sensing element of an oscillator system, and the shifts in the resonance frequency caused by velocity changes are measured [1, 17-19].

The measuring setup consists of the sensor delay line, chamber, electronic module, power supply, A/D converter and PC computer with specialized software. The sensor delay line has two independent waveguide channels placed on the lithium niobate substrate. One of them is covered by the sensor layer. The second one is the reference channel for temperature compensations. The operation frequency of both channels equals 70.3 MHz. This sensor line is installed in the chamber, equipped with the thermostating setup, a temperature sensor, inlet and outlet pipes. The constant temperature is kept in the chamber and the concentration of air-VOS atmosphere is controlled.

2. Experimental

Generally, the sensor response i.e. frequency shift Δf of the ultrasonic wave can be written as [1]:

The role of the electronic module is to generate the ultrasonic waves in both channels and to separate a difference frequency, i.e. the difference between the frequencies of both channels. The sensor delay line is a part of the oscillator with a positive feedback. The generation and stabilization circuits for both channels are identical. The accuracy of the difference frequency measurements using the electronic module equals 1 Hz. During measurements the difference frequency and temperature are recorded by the data acquisition setup. This setup consists of a two-channel A/D converter, a personal computer and software. The schematic diagram of the experimental set-up is presented in Fig.1.

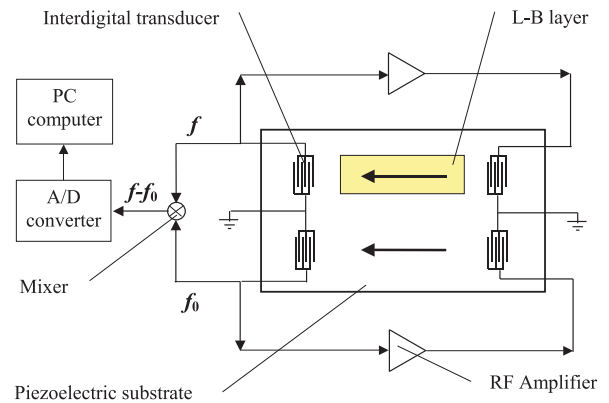

Fig. 1. Schematic diagram of the experimental set-up

The bicomponent monomolecular layer was prepared by the L-B method and deposited on one channel of the sensor delay line. The aqueous solution of cobalt bromide (0.5 mM) was applied as a subphase. The sensor layer was deposited by lowering the subphase level, i.e. by the horizontal method. The layer was fabricated from the equimolar mixture of 5-[[1,3-dioxo-3-[4-(1-oxooctadecyl)phenyl]propyl]amino]-1,3-benzenedicarboxylic acid (DA) and cetylamine (CA). The presence of CoBr_2 causes a modification of the layer structure by the formations of salts and 1,3-diketonate complexes of DA with Co^{2+} [20], what makes this layer very stable due to intermolecular interactions between the DA molecules. Subsequently, the cetylamine was removed from the layer by washing in chloroform. This process caused the formation of the

new material with the structure containing pores of the molecular dimensions with diameter distribution from 16 nm up to the diameter of hydrocarbon tail (0.2 nm).

The sensor was installed into the chamber. The chamber was filled by the mixture of air and the vapor of the VOS or by the clean air. The difference frequency was measured. During measurements, the temperature of the chamber and its interior containing the sensor delay line was kept constant ($35,00 \pm 0.05^\circ\text{C}$) by immersion into bath of the thermostat. After stabilization of the working conditions of the sensor delay line (a constant value of the difference frequency), the mixture of air and the vapors of the VOS at 300 ppm concentration was pumped into the chamber. 2-methylbutane (isopentane),

hexane and heptane have been chosen as tested VOS. After 20 minutes the chamber was filled by the clean air. In the two-second intervals of time, the response of the sensor i.e. the dependence of the difference frequency on time was recorded continuously by the data acquisition set-up.

3. Results and discussion

In Fig. 2, the plots of the difference frequency versus time are presented for 2-methylbutane, hexane and heptane. The frequency shifts result from the interaction of the mixtures of air and the VOS vapors with the sensing layer.

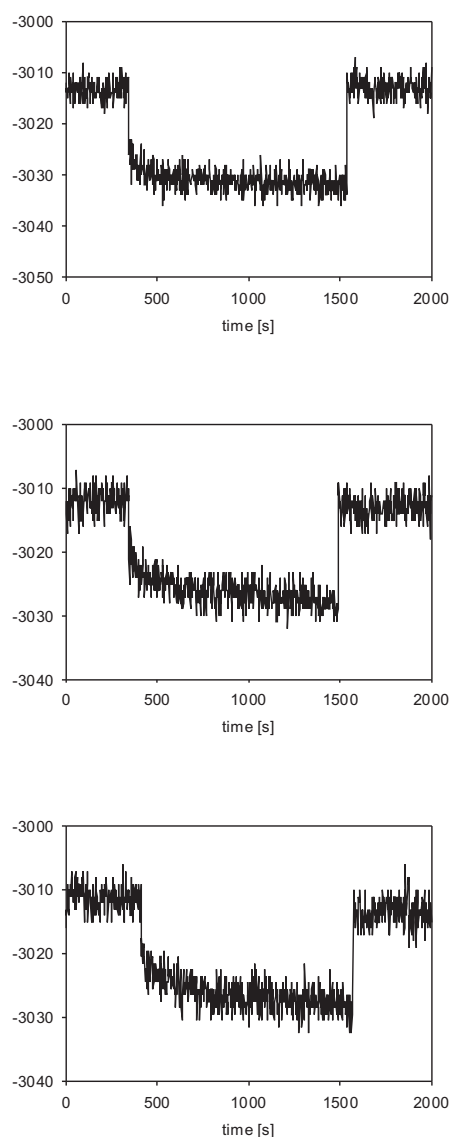

Fig. 2. Difference frequency versus time as response of the porous DA layer for action of the mixture of the vapors of VOS and air: (a) 2-methylbutane, (b) hexane and (c) heptane. The VOS vapour concentration equals 300 ppm

The analysis of the results allowed to determine values of the response parameters (see Table 1) of the sensor covered by the porous DA layer on the presence of VOS. It can be noticed that the decrease of the difference frequency after contact with the vapor-air mixture

has the lowest value for hexane and the highest one for 2-methylbutane. The diminution of this frequency in time behaves in opposite manner. More information can be obtained taking into account the molecular mass of VOS.

TABLE 1

Response parameters of the sensor delay line covered by the porous DA layer to the presence of the vapors of volatile organic solvents. Standard deviations of the decrease of difference frequency after contact with the VOS vapors and the diminution of difference frequency in time after contact with the VOS vapors are not greater than 1.2 Hz and $3 \cdot 10^{-4}$ Hz/s, respectively

Name of VOS	Decrease of difference frequency after contact with VOS [Hz]	Diminution of difference frequency in time after contact with VOS [10^{-3} Hz/s]
2-methylbutane	15.9	3.3
hexane	11.6	5.1
heptane	12.6	5.0

According to the formula (3) and the known expression $\Delta m = N_M \cdot (M/A_v)$, (where A_v , M , and N_M are the Avogadro's number, the molar mass of VOS and the number of adsorbed molecules of VOS, respectively) the number of the adsorbed molecules of VOS per surface of the sensing layer can be obtained:

$$\frac{N_M}{A} = -\frac{(\Delta f - \Delta f_0) \cdot A_v}{k_m \cdot f_0^2 \cdot M}, \quad (4)$$

where Δf_0 is the value of the difference frequency before action of the VOS vapor and air mixture on the layer. For lithium niobate $k_m = 5.49 \cdot 10^{-11} \text{ sm}^2\text{g}^{-1}$.

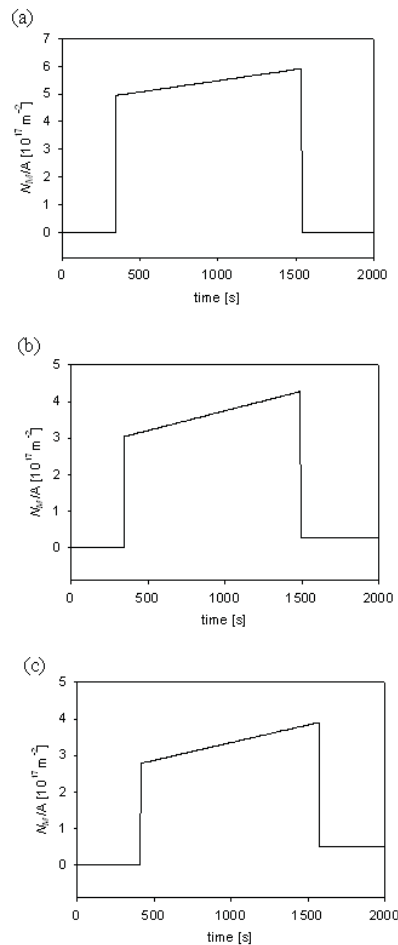

Fig. 3. Number of molecules per surface of the porous DA sensing layer, N_M/A . The submitted mixture contains 300 ppm of: (a) 2-methylbutane, (b) hexane and (c) heptane in air

TABLE 2

The numbers of adsorbed molecules of VOS per surface of the sensing layer, N_M/A , for the porous DA layer. Standard deviations of the N_M/A values are not greater than $0.2 \cdot 10^{17} \text{ m}^{-2}$

Name of VOS	Molar mass [g/mole]	N_M/A immediately after contact with layer [10^{17} m^{-2}]	N_M/A after 20 minutes contacting with layer [10^{17} m^{-2}]
2-methylbutane	72.15	4.9	5.9
hexane	86.18	3.0	4.3
heptane	100.20	2.8	3.9

The values of N_M/A are presented in Fig.3 and Table 2. Because of the fluctuations of the difference frequency the linear regression was applied for time before, during and after the action of the VOS vapor.

One can notice that the values of N_M/A in the instant of time immediately after contact of the VOS vapor with the layer and these measured after 20 minutes decrease in order: 2-methylbutane > hexane > heptane. This means that the adsorption of bigger molecules with the greater molecular mass by the porous sensing layer is more difficult than that of smaller ones. In the porous DA layer the holes open access to the side walls of hydrocarbon chains of the DA molecules increasing the active surface of the sensing layer for the smaller VOS molecules, especially for 2-methylbutane, which can easier penetrate these holes. Besides of it, the adsorption is possible on the surface between the holes for the VOS molecules of different dimensions by means of hydrophobic interactions. These facts cause quite different behavior of N_M/A values for the various VOS and can be used for the recognition of the kind of VOS by the SAW sensor with the tested sensing layer.

4. Conclusions

The porous Langmuir-Blodgett layer has been fabricated from the equimolar mixture of 5-[[1,3-dioxo-3-[4-(1-oxooctadecyl)phenyl]propyl]amino]-1,3-benzenedicarboxylic acid with cetylamine and by subsequently removing of cetylamine. This film has been investigated as the sensing layer of the SAW sensor for the vapors of 2-methylbutane, hexane and heptane in air.

The layer reacts to the vapors of 2-methylbutane, hexane and heptane at low concentration. This reaction is reversible. The reaction time is less than 2 seconds. The response parameters of the sensor i.e. the decrease of the difference frequency after contact of the vapor-air mixture with the layer and the diminution of this frequency in time, depend on the kind of the volatile organic solvents. The numbers of the adsorbed molecules of the volatile organic solvents per surface of the sensing layer have been calculated. The explanation of the observed

differences in the behavior of the layer in contact with the vapors of the volatile organic solvents has been proposed. From the obtained results and performed calculations it can be noticed that the smaller molecules have the larger values of N_M/A due to easier adsorption in the porous DA layer of the smaller molecules.

The obtained results confirmed the utility of the L-B chemosensing layers to develop the SAW sensors for the vapors of the volatile organic solvents.

REFERENCES

- [1] D. S. Ballantine, R. M. White, S. I. Martin, A. J. Rico, E. T. Zellers, G. C. Frye, H. Wohltjen, Acoustic wave sensors, Academic Press, San Diego 1997.
- [2] D. K. Schwartz, Langmuir-Blodgett film structure. Surface Science Reports **27**, 241-334 (1997).
- [3] B. Holcroft, G. G. Roberts, Surface acoustic waves sensors incorporating Langmuir-Blodgett films, Thin Solids Films **160**, 445-452 (1988).
- [4] J. Cirak, P. Kostial, J. Vajda, P. Tomcik, D. Barancok, L. Kelesi, Surface acoustic wave propagation in Langmuir-Blodgett layers, Appl. Surface Science **108**, 53-57 (1997).
- [5] M. Penza, E. Milella, M. B. Alba, A. Quirini, L. Vasaneli, Selective NH_3 gas sensor based on Langmuir-Blodgett polypyrrole film, Sensors and Actuators **B 40**, 205-209 (1997).
- [6] C. Di Natale, R. Paolesse, A. Macagnano, V. I. Troitsky, T. S. Berzina, A. D'Amico, Pattern recognition approach to the study of the interactions between metalloporphyrin Langmuir-Blodgett films and volatile organic compounds, Analytica chimica Acta **384**, 249-259 (1999).
- [7] K. H. Kang, J. M. Kim, D. K. Kim, S. B. Jung, J. S. Chang, Y. S. Kwon, Effect of pH on the properties of palmitic acid LB films for gas sensors, Sensors and Actuators **B 77**, 293-296 (2001).
- [8] M. Matsuguchi, T. Uno, Molecular imprinting strategy for solvents molecules and its application for QCM-based VOC vapour sensing, Sens.Actuators B, **113**, 94-99 (2006).
- [9] M. Penza, G. Cassano, P. Aversa,

- F. Antolini, A. Cusano, M. Con-sales, M. Giordano, L. Nicolais, Carbon nanotubes-coated multitransducing sensors for VOC's detection, *Sens.Actuators B*, **111-112**, 171-180 (2005).
- [10] S. Ichinohe, H. Tanaka, Y. Kanno, Gas sensing by AT-cut quartz crystal oscillator coated with mixed lipid film, *Sens.Actuators B*, **123**, 306-312 (2007).
- [11] D. A. Winterbottom, R. Narayanaswamy, I. M. Raimundo, Cholesteric liquid crystals for detection of organic vapours, *Sens.Actuators B*, **90**, 52-57 (2003).
- [12] T. Basova, E. Kol'tsov, A. K. Ray, A. K. Hassan A. G. Gürek, V. Ahsen, Liquid crystalline phtalocyanine spun films for organic vapour sensing, *Sens.Actuators B*, **113**, 127-134 (2006).
- [13] A. Macagnano, E. Sgreccia, R. Paolese, F. de Cesare, A. d'Amico, C. di Natale, Sorption and condensation phenomena of volatile compounds on solid-state metalloporphyrin films, *Sens.Actuators B*, **124**, 260-268 (2007).
- [14] M. Culha, N. V. Lavrik, F. M. Schell, C. A. Tipple, M. J. Sepaniak, Characterization of volatile, hydrophobic cyclodextrins derivatives as thin film for sensing applications, *Sens.Actuators B*, **92**, 171-180 (2003).
- [15] P. A. Lieberzeit, W. Greibl, H. Stathopoulos, F. L. Dickert, F. G. Fischerauer, W.-E. Bulst, Covalently anchored supramolecular monolayers on quartz surfaces for use in SAW sensors, *Sens.Actuators B*, **113**, 677-683 (2006).
- [16] F. L. Dickert, M. Reif, R. Sikorski, Chemical sensors for solvent vapours; enthalpic and entropic contributions to host-guest interactions, *J.Mol.Model*, **6**, 446-451 (2000).
- [17] M. von Schickfus, R. Stanze, T. Kammerreck, D. Weiskat, W. Dittrich, Improving the SAW gas sensor: device, electronics and sensor layer, *Sens.Actuators B*, **18/19**, 443-447 (1994).
- [18] W. Jakubik, M. Urbanczyk, E. Maciak, Metal-free phthalocyanine and palladium sensor structure with a polyethylene membrane for hydrogen detection in SAW systems, *Sens.Actuators B*, **127**, 295-303 (2007).
- [19] A. Balcerzak, G. Zhavnerko, Ultrasonic chemical sensor for detection of aliphatic and aromatic hydrocarbons in air, *Arch. Acoust.* **32**, 53-58 (Supplement) (2007).
- [20] G. K. Zhavnerko, V. V. Filipov, F. M. Severin, T. A. Kuchuk, V. E. Agabekov, Formation and features of skeletonized structures in two-component Langmuir-Blodgett films, *J. Coll. Interface Sci.* **193**, 1-7 (1997).